

## → Nagano E09AC

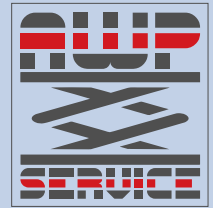

### Articulated crawler boom

Designed with AC motor and high-capacity battery, equivalent power and drive to diesel-powered model. Clean, quiet, low vibration, less heat generation. Ideal for urban construction; also suitable for underground, tunnel and indoor construction.



*We take service to a higher level*

### STANDARD FEATURES

- ✓ 360 °
- ✓ Zero tail swing
- ✓ Low ground pressure
- ✓ Grey non marking tracks
- ✓ Zero emission engine
- ✓ Extended battery performance, AGM maintenance-free battery.
- ✓ Hand pump emergency lowering system.

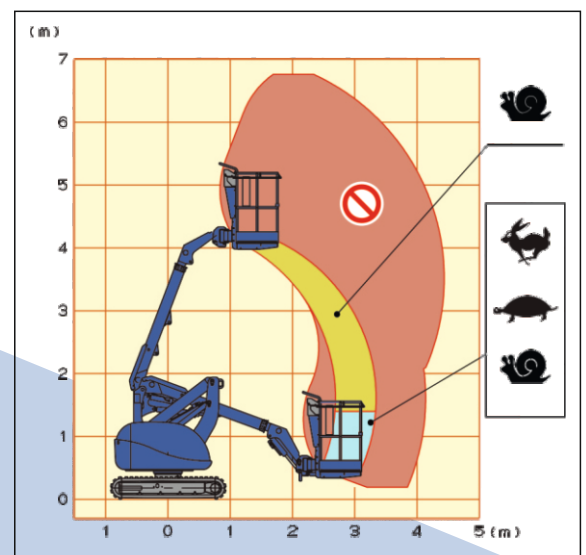
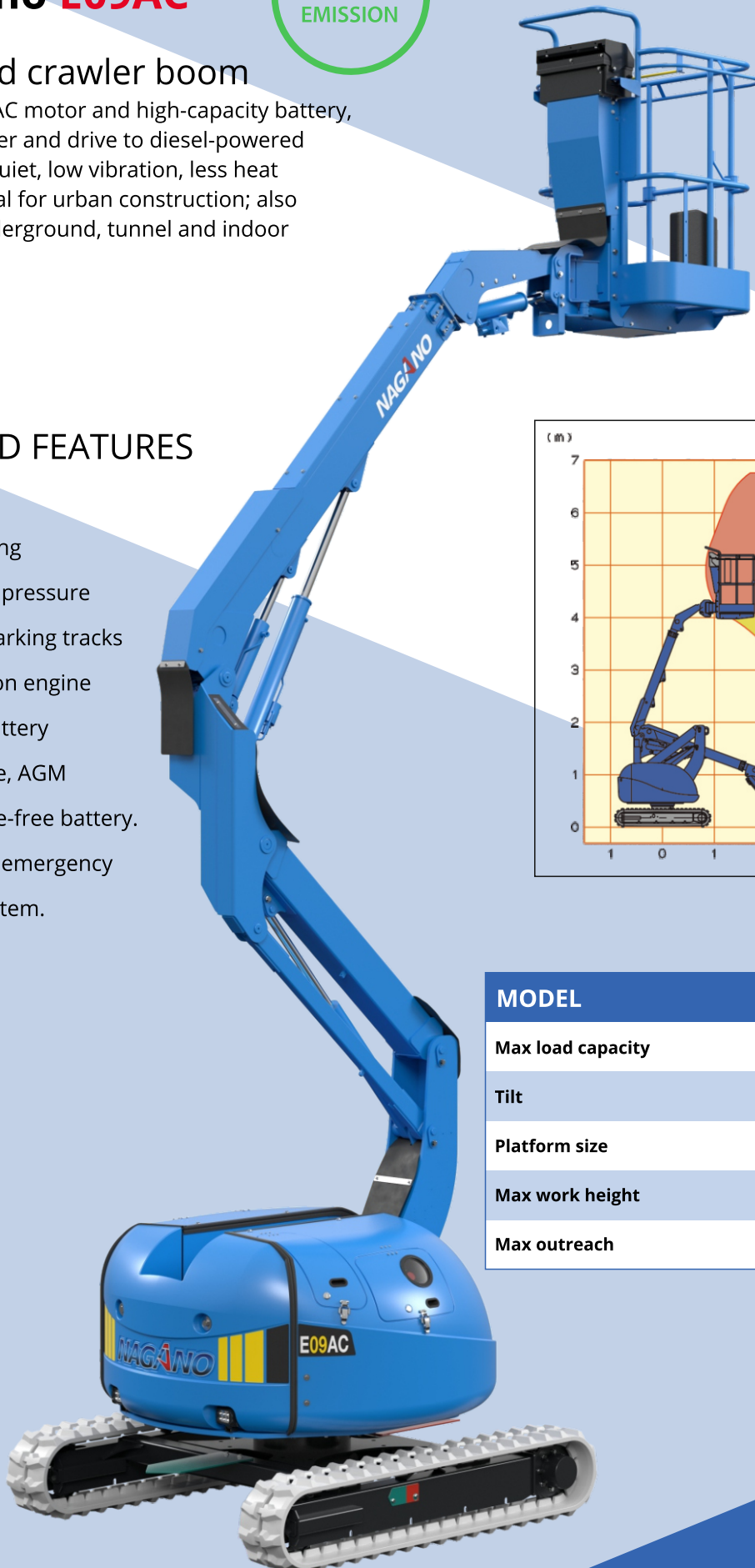

MODEL	E09AC
Max load capacity	150 kg
Tilt	5 °
Platform size	0,62 x 0,77 x 1,10 m
Max work height	8,80 m
Max outreach	4,45 m

MODEL		E09AC
SPECIFICATIONS	Max work height	8,80 m
	Max outreach	4,45 m
	Allowable tilt	5 °
	Max load capacity	150 kg
	Platform size (L x W x H)	0,62 x 0,77 x 1,10 m
	Swing angle basket	L90 ~ R40 °
	Transport dims (L x W x H)	3,70 x 1,65 x 2,00 m
	Machine weight	2.740 kg
TRA.	Travel speeds	0,7 / 1,1 / 2,2 km/h
POWER SOURCE	Engine type	AC 3 PHASE
	Rated power	5 kW
	Capacity	260 Ah
	System voltage	8 x 6 V
SAFETY DEVICES	Emergency stop	✓
	Food switch / Enabling switch	✓
	Auxiliary lowering control	✓
	Traveling restriction (on slope)	✓
	Operation restriction (on slope)	✓
	Battery isolator switch	✓
	LED lighting	✓*

\* rear + upper control box only

